

Mobile Robots

LD Series

Autonomous Mobile Robots (AMRs)

Omron mobile robots are fully autonomous intelligent vehicles that increase throughput, reduce machine dwell time, eliminate errors, improve material traceability, and allow employees to focus on tasks that require complex human skills. What's more, unlike traditional AGVs, our mobile robots navigate by the natural features of the facility and require no expensive facility modification

LD Series mobile robots are easy to get up and running, requiring no construction such as the installation of magnets, and minimal programming. In addition, our software integrates with your other systems so you can get the solution up and running in minimal time.

- Easy to setup and operate
- Works safely with people
- Autonomous navigation doesn't require preset routes, magnets, beacons or facility modifications
- Easy to integrate with MES, ERP, and WMS systems
- Able to operate in fleets of up to 100 robots



Part Number Configuration

37 1 2 3 - 4

1 Robot Type			Symbol
LD 60/ LD 90			0
Cart Transporter			1
LD 250			2
2 Speed & Payload			Symbol
0.9m/s (Excludes LD 250)	90Kg (LD90)		6
	130Kg (Cart transporter)		
1.2m/s (LD 250 Only)	250Kg		2
1.3m/s (Excludes LD 250)	90Kg (LD90)		4
	105Kg (Cart transporter)		
1.8 m/s/ (LD 60 Only)	60Kg		3
3 Laser version			Symbol
SICK (Excludes LD 250)			1
Omron			2
4 Configuration			Symbol
Protection	Applicable Versions	Bundle Contents	
Standard	LD 60 / LD 90 / LD 250	Robot	00000
		Robot, Dock	00002
		Robot, Dock, Joystick, Top Plate	10004
	Cart Transporter	Robot	00010
		Robot, Dock	00012
		Robot, Dock, Joystick, Top Plate, Acuity, Cart	01014
ESD	LD 60 / LD 90	Robot	20000
		Robot Dock	20002
		Robot, Dock, Joystick, Top Plate	20004

LD Series

Components and Functions

LD-60, LD-90

Light Discs

Status indicator is located on both sides.

Front Bumper

Stops when in contact with an obstacle.

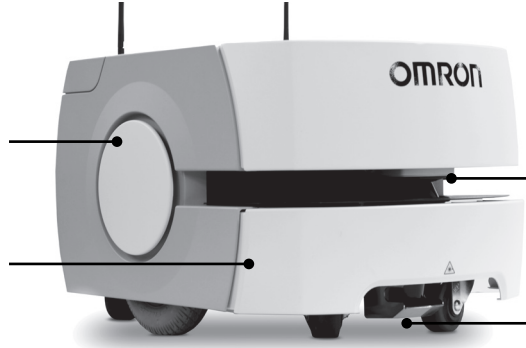

Safety Scanning Laser

Safety-rated laser used for SLAM (Simultaneous Localization and Mapping) and safety functionality.

Low Front Laser

Obstacle sensor detects low-profile objects when moving forward.



*ESD Model Shown

AUX Power & I/O

Internal connections to power and control custom topper models.

Operation Panel

Access to system power, E-Stop, and the operation status display.

Rear Sonar

Detects rear obstacles using sonar.

Performance Battery

Up to 15 hours of runtime between charges for up to 7 years.

Charge Dock

Integrated contacts for automated charging.



Components and Functions

LD-250

Light Discs

Status indicator is located on both sides.

E-Stop Buttons

E-stop located on both sides and top.

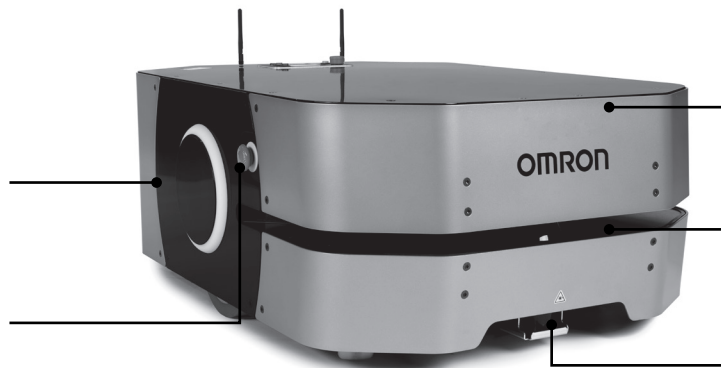

Hardened Construction

Metal chassis and skins for increased duty and durability.

Safety Scanning Laser

Safety-rated laser used for SLAM (Simultaneous Localization and Mapping) and safety functionality.

Low Front Laser

Obstacle sensor detects low-profile objects when moving forward.

Aux Power & I/O

Internal connections to power and control custom topper modules.

Performance Battery

Up to 13 hours of runtime between charges for up to 7 years.

Rear ToF Sensors

Detects rear obstacles using infrared light.



Operation Panel

Access to system power, E-Stop, and the operation status display.

Charge Dock







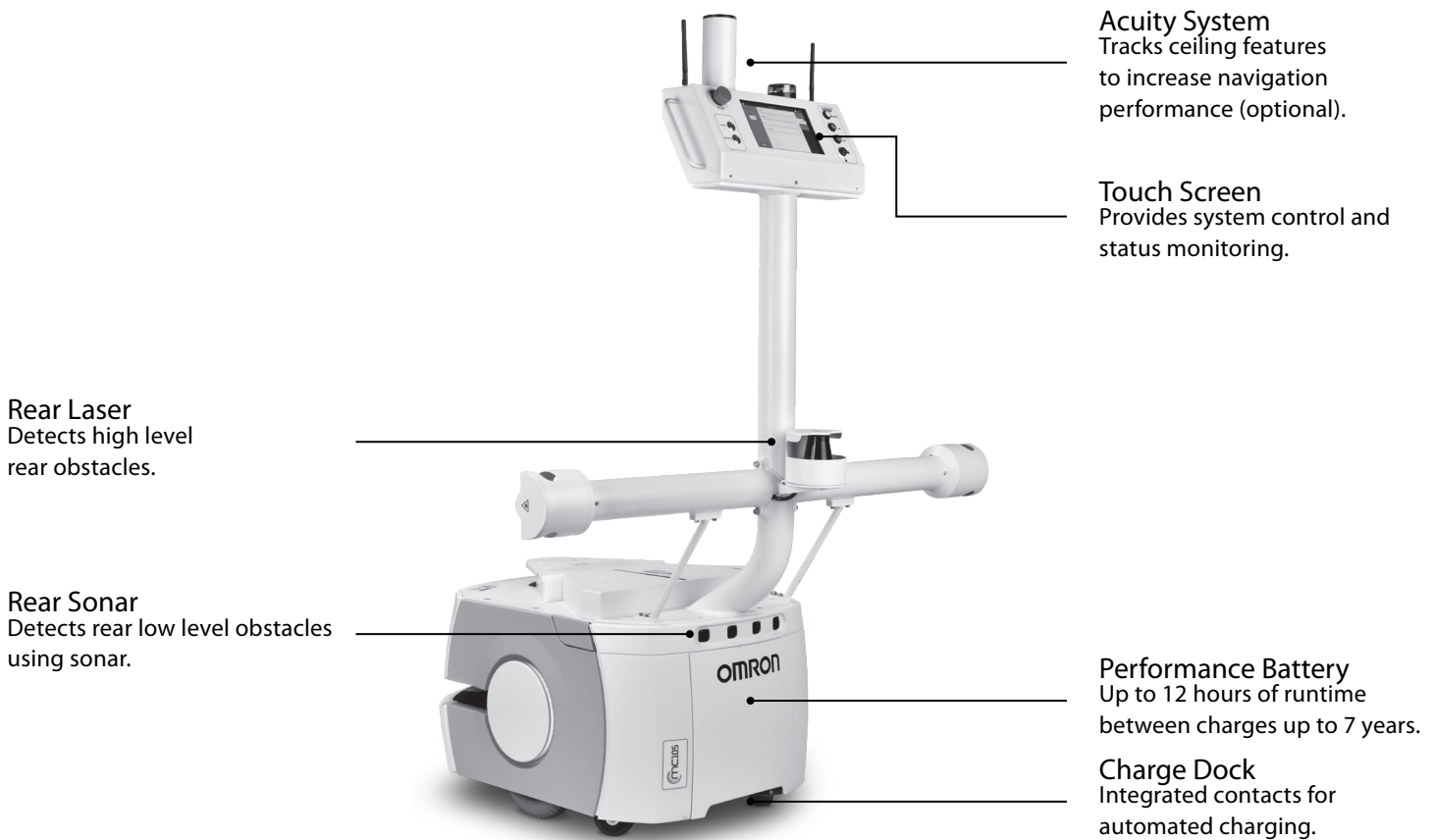
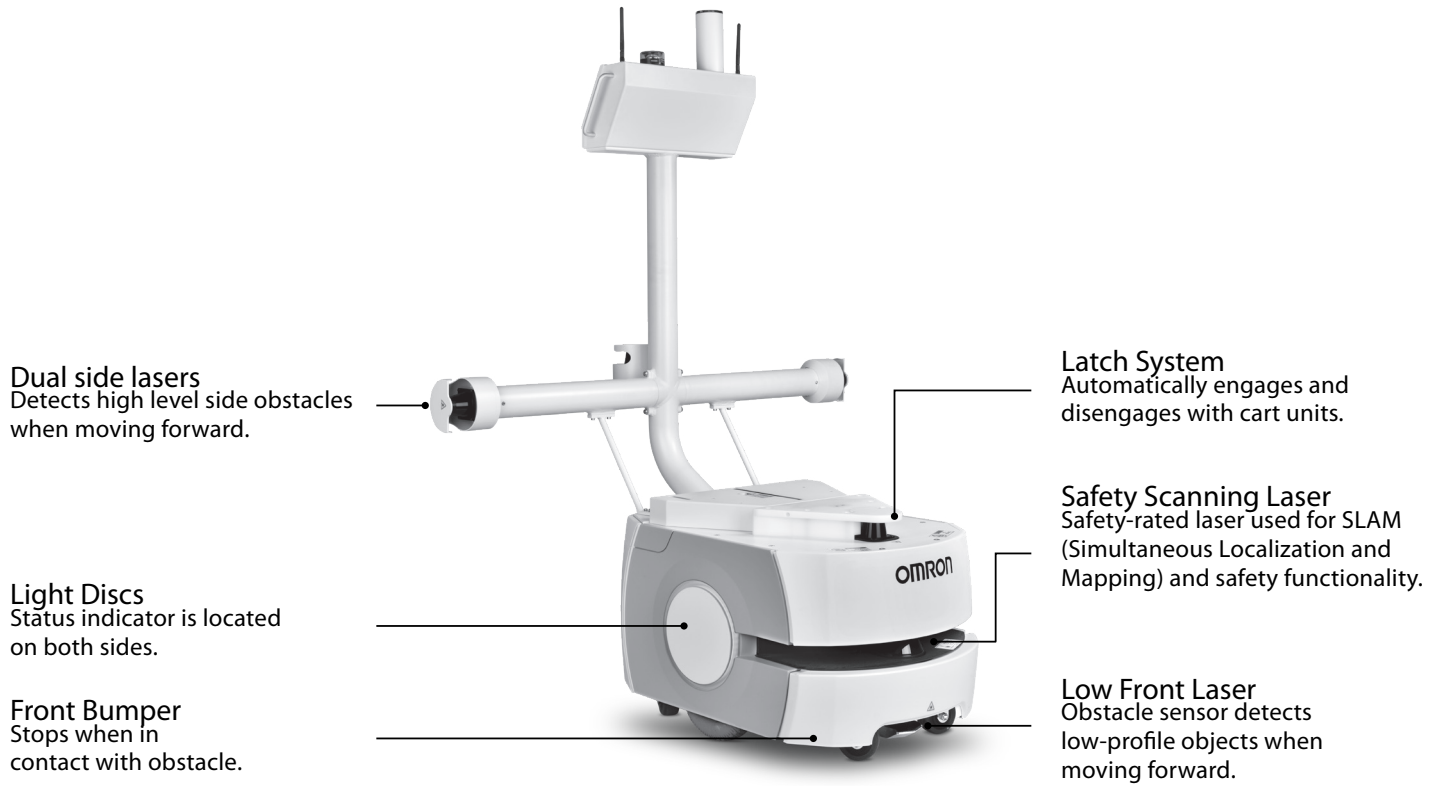

Integrated contacts for automated charging.







Components and Functions

Cart Transporter





LD Series Options and Accessories

Appearance	Description	Specification	Configuration & Attachment	Part Number
 <p>High Accuracy Positioning System (HAPS)</p>	<p>A combination of sensor and magnetic tape to achieve accurate alignment during forward driving motion, when the sensor is attached to mobile robot and magnetic tape is on the floor.</p>	Single sensor - LD-60/ LD-90	Sensor × 1, mounting bracket × 1, power connector × 1, RS-232 connector × 1, 25 mm wide magnetic tape (south top side, 50 m roll)	13660-100
		Double sensor - LD-60/ LD-90	Sensor × 2, mounting bracket × 2, power connector × 1, RS-232 connector × 2, 25 mm wide magnetic tape (south top side, 50 m roll)	13660-000
		Single sensor - LD-250	Sensor × 1, mounting bracket × 1, power connector × 1, RS-232 connector × 1, 25 mm wide magnetic tape (south top side, 50 m roll)	21374-100
		Double sensor - LD-250	Sensor × 2, mounting bracket × 2, power connector × 1, RS-232 connector × 2, 25 mm wide magnetic tape (south top side, 50 m roll)	21374-000
Magnetic tape	Magnetic tape for the High Accuracy Positioning System. The tape is applied to signal the mobile robot where to stop	25 mm wide magnetic tape (south top side, 50 m roll)		14925-000
 <p>Cell Alignment Positioning System (CAPS)</p>	<p>Add on software license that improves the AMR's positional accuracy</p>	Software license	USB dongle with CAPS activated license for LD 60/90 and Cart Transporter	20271-805-OEI-69C
			USB dongle with CAPS activated license for LD 250	20271-805-OEI-250
 <p>Acuity Localization</p>	<p>Upwards facing camera that maps ceiling features/lights used where process layout or obstacle location changes often. Installed on a payload structure attached to the mobile robot.</p>		Camera, mounting kit, cables, leveling kit	13700-000
			Camera, mounting kit, cables	13700-100
 <p>Touchscreen</p>	<p>Allows operators to check the status of the mobile robot, enter goals, and pause the mobile robot. Installed on a payload structure attached to the mobile robot.</p>	-	<p>Touchscreen with bracket, power supply with bracket, power cable from core to power supply (33 cm), power cable from power supply to touchscreen (183 cm), Ethernet cable between touchscreen and core (153 cm), gasket between touchscreen and AMR mounting surface, software package including touchscreen support</p>	13605-000
 <p>Side Laser</p>	<p>Used to detect obstacles that are at heights the safety scanning laser of the mobile robot cannot detect. Installed on a payload structure attached to the mobile robot.</p>	Bundle	Laser × 2, cable × 1	13456-000
		Kit	Laser × 2, Cable × 1, mounting kit × 2, metal cover × 2	13456-100
 <p>Call/Door Box</p>	<p>Used to issue a request for a mobile robot to go to the goal or to open a closed door. Installed at the goal or door</p>	WiFi	Call/door box	13029-802
		Wired	Call/door box	13029-902
 <p>Battery</p>	<p>A battery that is installed in the mobile robot</p>	72 Ah Battery cell nominal capacity	Battery - LD-250	20452000
 <p>AMR Legacy Upgrade Dongle</p>	<p>USB license dongle for AMRs migrating from MMS 4.x to FLOW Core</p>	-FLOW Core	USB dongle with 5 year FLOW Core license (Only for AMRs migrating from MMS 4.x to FLOW Core)	20271-301-OEI-5
		-FLOW Core -CAPS	USB dongle with 5 year FLOW Core license and CAPS license (Only for AMRs migrating from MSS 4.x to FLOW Core)	20271-301-805-OEI-5

Appearance	Description	Specification	Configuration & Attachment	Part Number
 Docking Station	A docking station to charge the battery installed in the mobile robot.	–	Docking station, AC power cable	12477-000
		Extended Wall mount	Docking station, AC power cable, extended wall mount (for Cart Transporter)	12477-050
 Joystick	Used for manually controlling the mobile robot	Cable length: 0.6 to 3 m	–	13558-000
 Breakout Cable	A D-SUB44 pin cable for digital I/O interface of the mobile robot.	–	DB44HD breakout cable (D-SUB44 pin cable for digital I/O interface)	14165-000
 Top Plate - LD-60, LD-90	A upper plate of the mobile robot OEM. It is not necessary for building customer payload	Top cover for OEM type	LD-60 LD-90	12944-000
 Top Plate - LD-250	A upper plate of the mobile robot OEM. It is not necessary for building customer payload	Top cover for OEM type	LD-250	20458-002
 Cart*	A cart designed to work seamlessly with the mobile robot cart transporter.	–	The cart only applies to LD-CT models.	75020-000
 Battery charging cable	A cable to connect a battery and docking station to charge the battery outside of the mobile robot	Cable length: 0.45 m	–	12676-000L

Fleet Management Solutions

Appearance	Product Name	Specification	Configuration & Attachment	Part Number
	Primary Fleet Manager		EM2100 Appliance with 5 year Fleet Operations Workspace License	20271-900-OEI-5
	Secondary Fleet Manager		EM2100 Appliance with 5 year Fleet Operations Workspace License	20271-901-OEI-5
	Replacement Enterprise Manager		EM2100 Replacement Unit. (Must use license dongle from outgoing EM2100)	1168-200F
	MobilePlanner	Version 4.x	Installer (USB)* License Dongle MSS 4.x compatible only (NOT COMPATIBLE with FLOW Core)	13495-200

* To obtain the latest version of the Fleet Operations Workspace (FLOW) Core software, contact your local OMRON representative.

Specifications

Mobile Robots-LD Platform LD-60, LD-90, LD-250, and Cart Transporter

Item	LD-60, LD-90		LD-250	Cart Transporter		Note
	37032-□□□□	37042-□□□□	37222-□000□	37142-□□□□	37162-□□□□	
Materials	Polycarbonate		Aluminum	Polycarbonate		
Dimension (L × W × H)	699 × 500 × 383 mm *1		963 × 718 × 383 mm *1	894 × 1074 × 1394 mm *2		*1 Height to top plate *2 Height includes WiFi antenna
Weight (with Battery)	62 kg		148kg (with battery) 129kg (without battery)	81 kg (Vehicle)/23 kg (Cart)		
Environment						
Ambient temperature	5 to 40 °C					
Ambient humidity	5 to 95 % (non-condensing)					
Operating Environment	Indoor usage only, no excessive dust, no corrosive gas					Direct sunlight may cause safety laser false positive
IP rating	IP20					
Cleanroom rating	Fed Class 100, ISO Class 5			None		
Floor Conditions						
Floor Requirements	Linoleum, epoxy, or concrete (no water, no oil, no dirt)					
Minimum floor flatness	FF25 (ACI 117 standard)*3					*3 ACI 117 is the American Concrete Institute standard for concrete floors. FF is flatness, FL is the level. Higher FF numbers represent flatter floors. FF25 is a fairly lenient specification.
Traversable step	15 mm max*4	10 mm max*4	10 mm max *5	5 mm max. *6	5 mm max. *6	*4 A speed of 250-300 mm/s and 250 mm/s, for the LD-60 and LD-90, is required for these steps. Faster or frequent driving over such steps or gaps will shorten the lifespan of the drivetrain components. Lower speeds may not traverse the step. Steps should have smooth, rounded profiles. *5 For LD-250, the robot should traverse the 10mm step at 600 mm/s or slower for best performance of the laser and battery *6 The Cart Transporter with a cart is capable of driving over a gap or step of 5 mm at a speed of 250 mm/s, but this should not be regarded as normal use. Regular driving over such gaps or steps will shorten the lifespan of the drivetrain components.
Traversable gap	15 mm max	15 mm max	15 mm max	5 mm max. *6	5 mm max. *6	
Climb grade	Below 1: 12 (60 kg max.) Flat floor only (over 60 kg)		Flat floor only (full payload)	Flat floor only		
Navigation						
Routing	Autonomous routing by localizing with safety scanning laser based on environment mapping					
Environmental map making method	Scan by walking the mobile robot through the environment, and upload the scan data in the MobilePlanner					
Payload						
Maximum Weight	60 kg	90 kg	250 kg	105 kg*7	130 kg*7	*7 Excluding cart weight
Mobility						
Maximum Speed	1800 mm/s	1350 mm/s	1200mm/s	1350 mm/s	900 mm/s	
Maximum Rotation Speed	180°/s	180°/s	120°/s	100°/s		

Item	LD-60, LD-90		LD-250	Cart Transporter		Note
	37032-□□□□	37042-□□□□	37222-□000□	37142-□□□□	37162-□□□□	
Stop Position Accuracy	± 100 mm position*8, ± 2° rotation					*±10 mm position, ±0.5° rotation with HAPS option ±25 mm position, ±1.0° rotation with CAPS option
Drive wheel						
Materials	Non-marking nylon foam-filled rubber, non-conductive		Aluminum with polyurethane tread	Non-marking nylon foam-filled rubber, non-conductive		
Size	200 dia. × 50 mm nominal, 2 wheels					
Passive caster						
Materials	Conductive thermoplastic rubber on polyolefin		Conductive solid polyurethane	Conductive thermoplastic rubber on polyolefin		
Size	75 dia. × 41 mm nominal, 4 casters		127 dia. × 51 mm nominal, 4 casters	75 dia. × 41 mm nominal, 4 casters		
Power						
Battery	22-30 VDC					Lithium iron phosphate (LiFePO ₄)
Capacity	72 Ah Battery cell nominal capacity					
Run Time	15 hours (continuous) approx.		13 hours (continuous) approx	15 hours (continuous) approx.		With no payload condition
Recharge Time	4 hours (5:1 ratio) approx.					
Battery Life Cycles	2,000 recharge cycles (battery cell nominal)					
Charging Method	Automatic / manual					
Auxiliary Power	5 VDC±5%, 1 A switched Aux power 12 VDC±5%, 1 A switched Aux power 20 VDC±5%, 1 A switched Aux power 22-30 VDC, 4 A switched × 2 22-30 VDC, 10 A switched*10 22-30 VDC, 10 A safe, switched*10					5, 12, 20, and 22-30 VDC power can be provided to external devices *10. 10 A switched and 10 A safe, switched share the 10 A of current
Standard						
Harmonized Standard	EN ISO 12100 / EN ISO 13849-1 / EN 60204-1					
Relevant Standard	EN 1525 / ANSI B56.5					
Wireless	IEEE 802.11 a/b/g					
Safety Features						
Safety Scanning Laser	1 at front Class 1 PLd safety per ISO13849-1 3 m maximum radius from laser for safety zones 40 m radius for general sensing 240° field of view					
Emergency Stop	1 at operator panel		1 at operator panel, 1 on each side (3 total)	1 at HMI post touchscreen, 1 at operator panel		
Rear Sonar	2 at rear, 2 m range		Time of flight (TOF) sensors	2 at rear, 2 m range		Each pair includes one emitter and one receiver working together
Front Bumper	1 at front of platform, 2 pairs of sensors		Fixed, non-sensing	1 at front of platform, 2 pairs of sensors		
Low Front Laser	1 at front of platform Class 1 4 m maximum range 126° field of view					
Side Laser	Option*11			2 on horizontal tubes of HMI post Class 1 4 m maximum range 270° field of view		*11. 2 on sides of payload structure, usermounted
Indicators	Light disc on each side			Light disc in each side, beacon on HMI post		
Speaker	3.5 in., 80 W max.					
Operator Interface						
Screen / Touch Panel	3.5 in. TFT 320 × 240 pixels, color screen			7.0 in. TFT LCD touch panel, 18/24 bit RGB		
Button	On button: green Off button: red Brake-release button: orange Keyswitch (disabled off button) *12			On button: green Off button: red Brake-release button: orange Keyswitch (disabled off button) *12, Latch button, unlatch button		*12. Key switch can be used to disable the off button to avoid accidental shutdown or tampering.
User Interface						
Wireless	IEEE 802.11 a/b/g					
Ethernet Port	1 x user LAN, 1 x maintenance LAN, Auto-MDIX					
Serial	RS-232 × 2					
Digital I/O	16 inputs, 16 outputs					
Analog I/O	8 inputs (0 to 30 V), 4 outputs (0-20 V)					
Audio	Digital audio out, audio in / audio out					
Cart Latching						
Latching Method	Not available			Automatic		

MobilePlanner Software

Operating System	Windows 10 (32-bit/64-bit version)
CPU	1.5 GHz dual-core CPU recommended
Main Memory	1.5 GB min. (4 GB min. recommended)
Hard Disk	At least 200 MB of available space
Video Memory	256 MB min.
Display	XGA 1024 × 768, 16 million colors
Supported Languages	Japanese, English, German

Fleet Manager

Dimensions - W × D × H	430 × 495.3 × 43.7 mm
Weight	9.1 kg
Mounting method	1U rack mount in a standard 19-inch equipment rack
Power Supply	100-240 VAC (typical 100 W)
Power Consumption	200W max.
Operating Temperature	10 to 35 °C
Storage Temperature	-25 to 60 °C
Operating Humidity	8 to 90%, non-condensing
Storage Humidity	5 to 95%, non-condensing
Chassis protection class	IP20
CPU	Intel® Xeon® CPU
Main Memory	32 GB DDR3
Storage	60 GB SSD
Archive Storage	4 TB HDD
Communication port	10/100/1000 Ethernet × 4, USB × 4, VGA
Status Display	Multi-segment LCD

High Accuracy Positioning System

Part Number	13660-□□00 (LD-60/90/105CT/130CT) 21374-□□00 (LD-250)	
Sensor	Depth	30 mm
	Width	160 mm
	Rating	IP64
	Environment	-40 to 85 °C
	LEDs	Power, tape present, left marker, right marker
Magnetic Tape	Width	25 mm
	Orientation	South up
Markers (Magnetic Tape)	Length	25 mm
	Orientation	300 mm min. for 500 mm/s drive speed North up
	Separation From Tape	15 - 30 mm
Connections	Front Sensor	RS232-1 (/dev/ttyUSB9) on the core
	Rear Sensor	RS232-2 (/dev/ttyUSB10) on the core
	Power, Both Sensors	Aux power using the included splitter cable

Acuity Localization

Part Number	13700-□□00
Field of View	140°
Power Input	12 VDC (±10%) supplied from platform through power connector
Power Consumption	3.3 W maximum

Cell Alignment Positioning System (CAPS)

Stop Position Accuracy	* ±25 mm position, ±1.0° rotation
Type	Software license

Touchscreen

Part Number	13605-000
Touch Panel	PCAP touch sensor, black-bordered cover lens
TFT Display	TFT LCD panel, 18/24 bit RGB parallel interface, 7.0 in. WVGA - wide viewing angles, 5-touch
Backlight	Constant current LED supply
Power Input	5 VDC supplied through power connector
Power Consumption	6.5 W maximum

Call/Door Box

Part Number	WiFi	13029-802
	Wired	13029-902
Dimensions - W × D × H	141.4 × 74.7 × 30 mm	
Weight	190 g	
Mounting method	Mount to the provided wall frame with four screws	
Power Supply	12 VDC	
Power Consumption	0.5 A, 6 W typical	
WiFi	IEEE 802.11 a/b/g/n	
Communication Port	Ethernet	
I/O	Input × 2, output × 2 (30 VDC, 2 A max.)	

Battery

Run Time (No Payload)	15 hours (continuous) approx. (LD-60/90)
	13 hours (continuous) approx. (LD-250)
Weight	19 kg
Voltage	22-30 VDC
Capacity	72 Ah (battery cell nominal)
Recharge Time	4 hours approx.
Life Expectancy	2,000 times 80% DOD (battery cell nominal), 7 years, approx., 16 hrs/day, 5 days/wk 4 years, approx., 19/7 (full-time)

Docking Station

Part Number	12477-000, 12477-050
Current	8 A*1
Contacts	2
Power	100 to 240 VAC, 50 to 60 Hz
Power Consumption	800 W
Humidity	5 to 95 %, non-condensing
Temperature	5 to 40° C
Dimensions (W × D × H)	349 × 369 × 315 mm 495 × 495.5 × 317 mm (with floor plate)
Weight	8.2 kg
Mounting	Wall bracket, directly to floor, or on floor with floor plate
Indicators	Power on: blue Charging: yellow
Connector	For out-of-platform battery charging

*1 Thermal fuse in AC power switch (10 A time-lag fuse at switch for legacy)

Joystick

Part Number	13558-000
Weight	0.55 kg
IP Rating	IP56

Cart

Part Number	75020-000
Dimensions (L × W × H)	592 × 846 × 480 mm
Weight	23 kg
Rating	ESD-rated
Passive Casters	2 front, 2 rear, spring-loaded
Caster Diameter	100 mm nominal
Caster Brakes	At 2 rear casters

Dimensions

CAD data can be downloaded from Omron's website.
<https://automation.omron.com/en/us/support/cad-library>

(Unit: mm)

Mobile Robots-LD Platform LD-60, LD-90

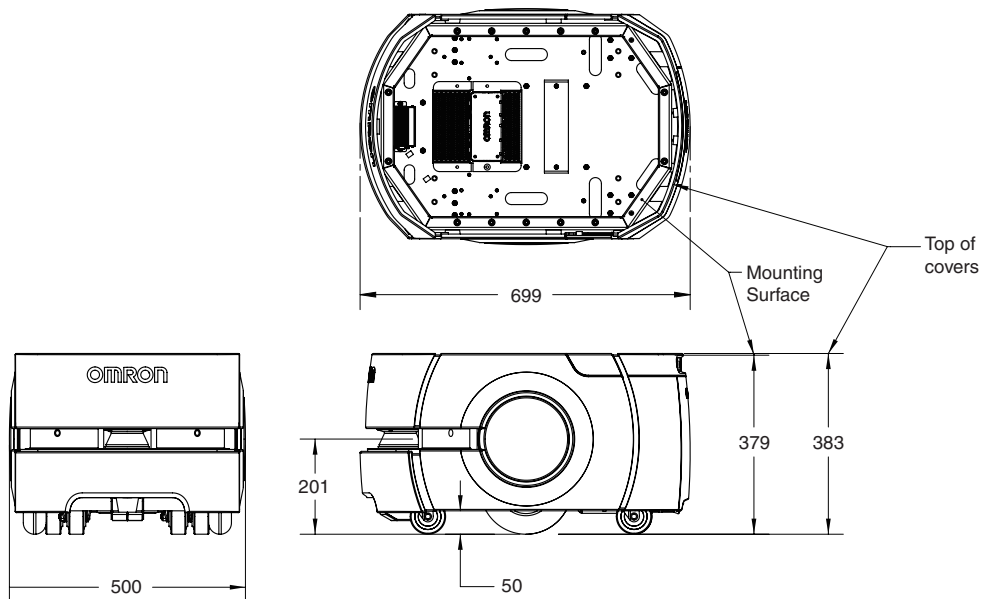

LD-250

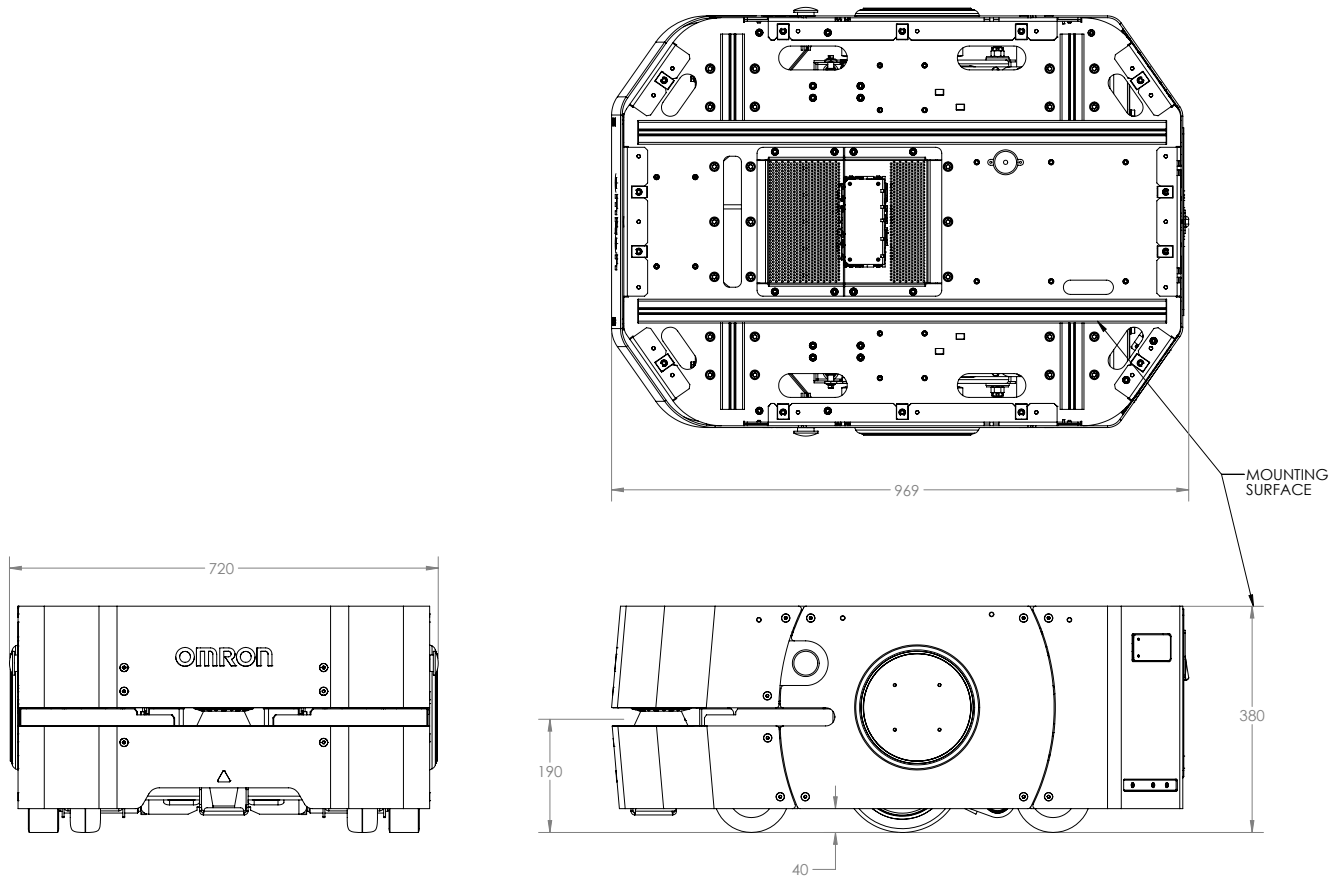

Dimensions

(Unit: mm) v

Cart Transporter

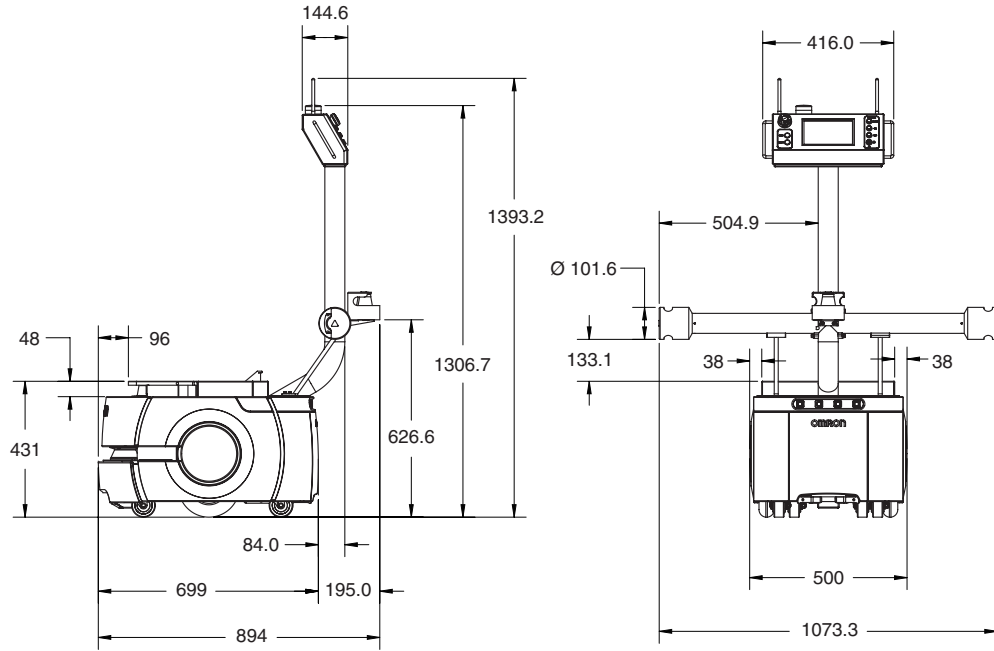

Fleet Manager EM2100 Appliance

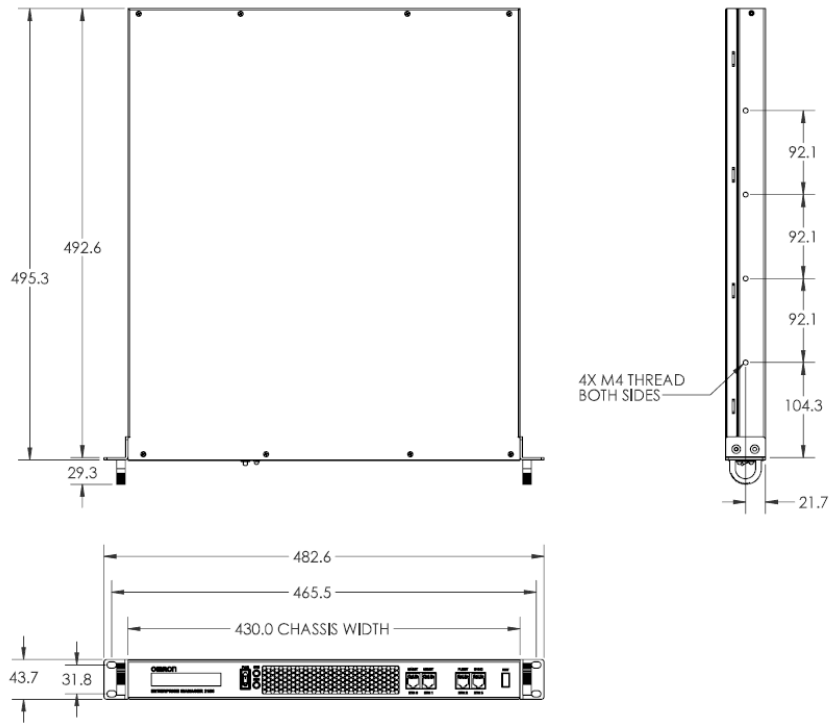
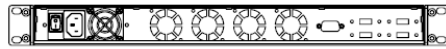

Dimensions

High Accuracy Positioning System

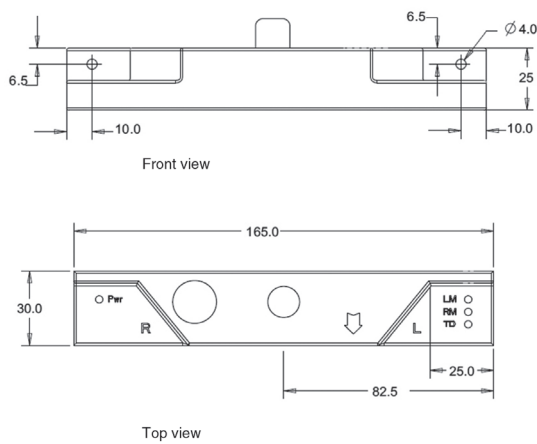

Docking Station

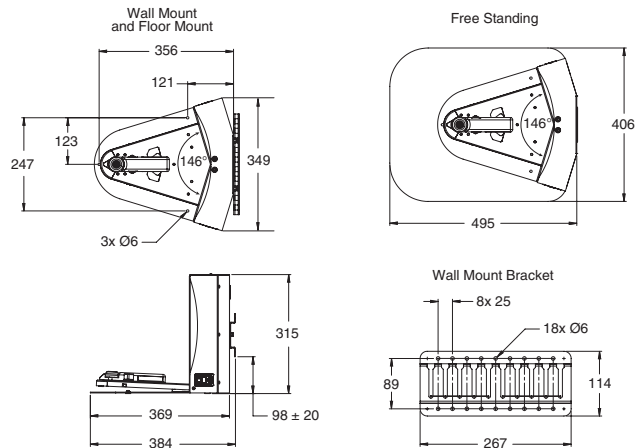

Acuity Localization

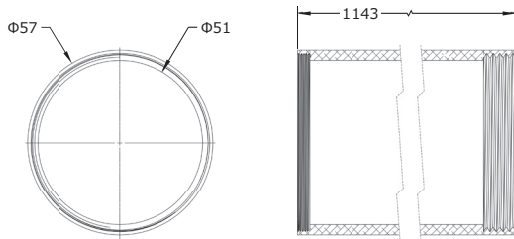

Joystick

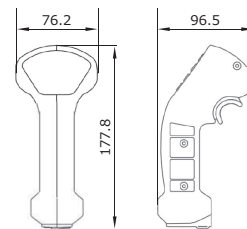

Touchscreen

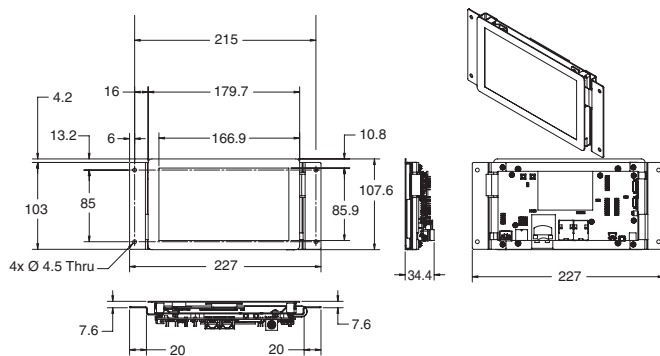

Call/Door Box

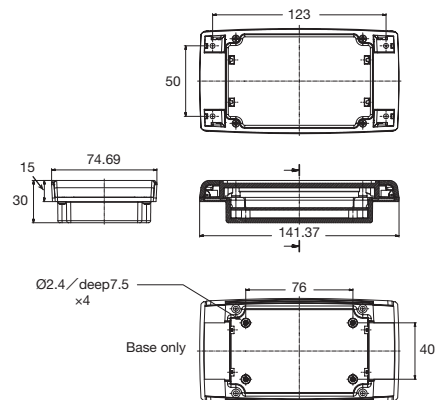

Cart

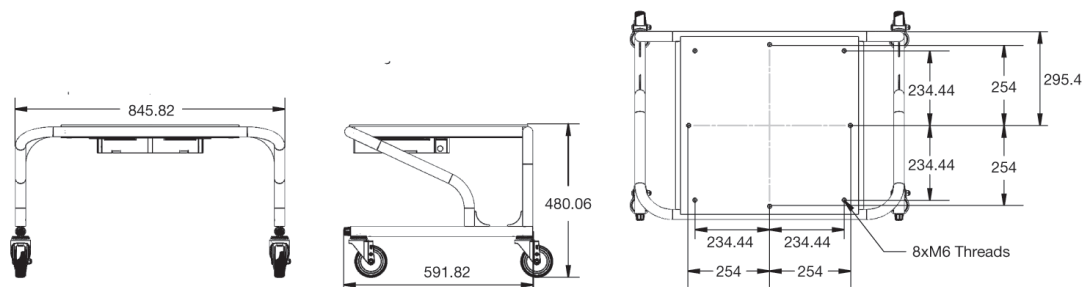

Related Manuals

Manual No.	English Title
I611	Mobile Robots LD Platform User Guide
I612	Mobile Robots LD Cart Transporter User Guide
I613	Mobile Robots LD Platform Peripherals Guide
I614	Mobile Robots Software Suite User Guide
I615	Enterprise Manager User Guide
I616	Mobile Robot LD Safety Guide
I617	Advanced Robotics Command Language Reference Guide
I618	Advanced Robotics Command Language Enterprise Manager Integration Guide
I634	EM2100 Installation Guide
I635	Fleet Operations Workspace Core User Guide
I636	Fleet Operations Workspace Core Migration Guide
I637	Fleet Operatiom Workspace Core Integration Toolkit User Guide
I642	LD-250 Platform User Guide

- Intel, Xeon and Intel Xeon are trademarks of Intel Corporation in the U.S. and/or other countries.
- Other company names and product names in this document are the trademarks or registered trademarks of their respective companies.
- The product photographs and figures that are used in this catalog may vary somewhat from the actual products.
- Microsoft product screen shot(s) reprinted with permission from Microsoft Corporation.

OMRON AUTOMATION AMERICAS HEADQUARTERS • Chicago, IL USA • 847.843.7900 • 800.556.6766 • automation.omron.com

OMRON CANADA, INC. • HEAD OFFICE

Toronto, ON, Canada • 416.286.6465 • 866.986.6766 • automation.omron.com

OMRON ELECTRONICS DE MEXICO • HEAD OFFICE

Ciudad de México • 52.55.5901.4300 • 01.800.386.6766 • mela@omron.com

OMRON ELECTRONICS DE MEXICO • SALES OFFICE

San Pedro Garza García, N.L. • 81.12.53.7392 • 01.800.386.6766 • mela@omron.com

OMRON ELECTRONICS DE MEXICO • SALES OFFICE

Eugenio Garza Sada, León, Gto • 01.800.386.6766 • mela@omron.com

OMRON ELETRÔNICA DO BRASIL LTDA • HEAD OFFICE

São Paulo, SP, Brasil • 55 11 5171-8920 • automation.omron.com

OMRON ARGENTINA • SALES OFFICE

Buenos Aires, Argentina • +54.11.4521.8630 • +54.11.4523.8483
mela@omron.com

OTHER OMRON LATIN AMERICA SALES

+54.11.4521.8630 • +54.11.4523.8483 • mela@omron.com